

D:20-1B PCB B02 D:200109
D:20-1B PCB B02 D:200119

LITE FUJIER ENTERRICE			
Title			
06/06NMIDDLE I / OBOARD			
Size	Document Number	Rev	
C	D:20-1AS DSN	A	
Date:	Tuesday, August 06, 2002	Sheet	2 of 3

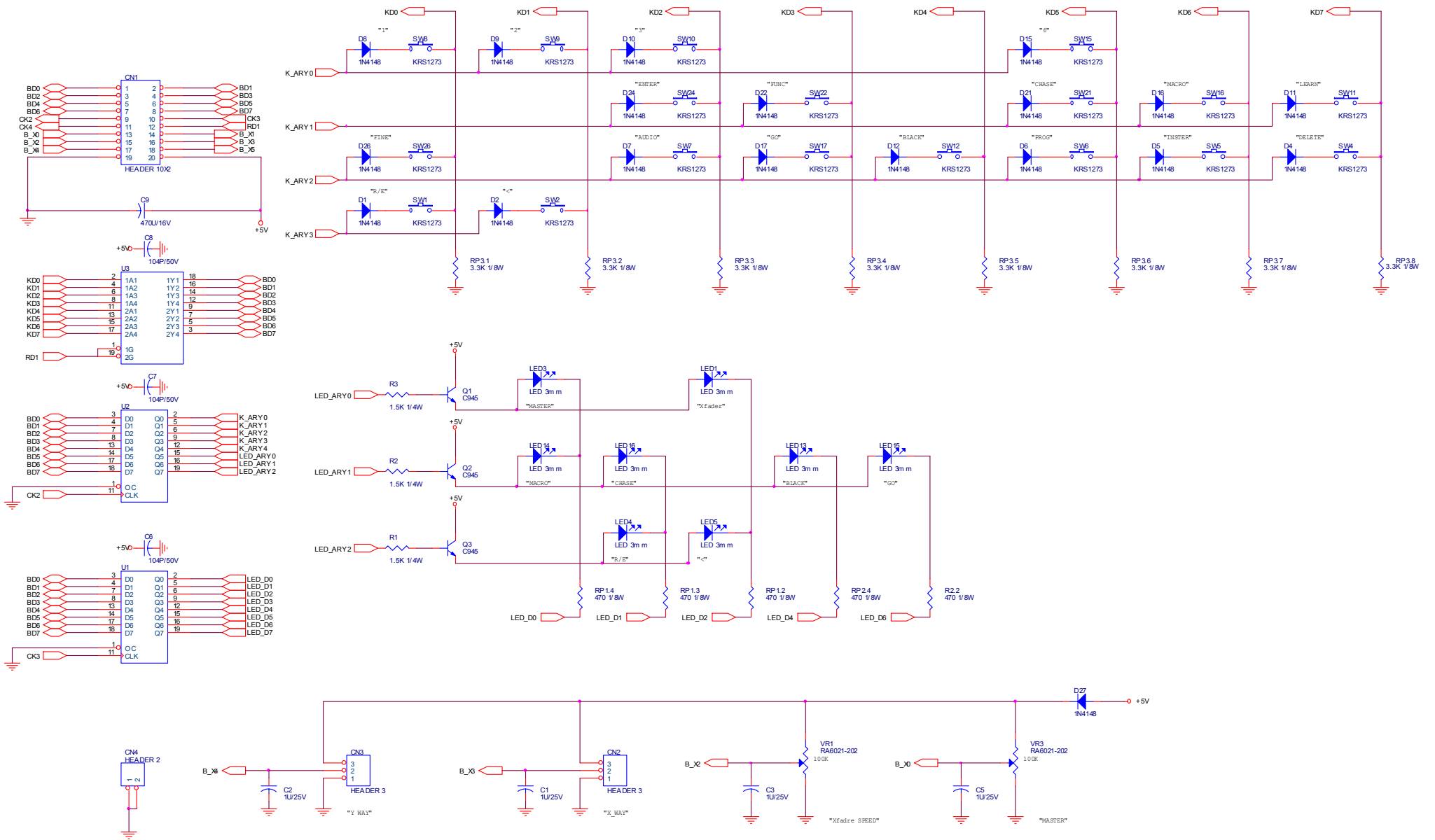

D20-2B R3/E2 D2028	
LITERATURE	
CAN DALI DRIVER BOARD / O2	
File	Rev a
Size C	Date: Tuesday, August 06, 2013
Document Number	Sheet 4 of 4

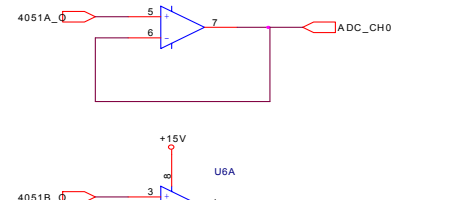
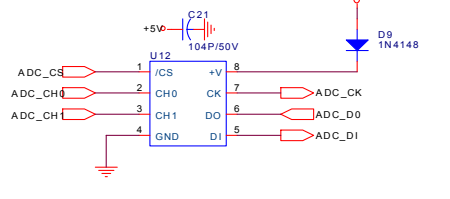
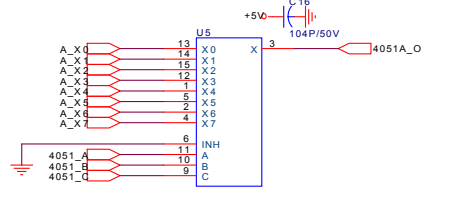
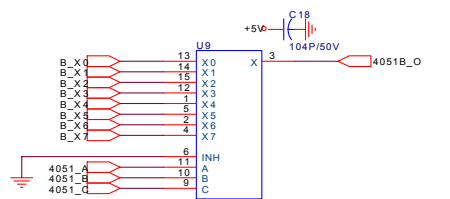
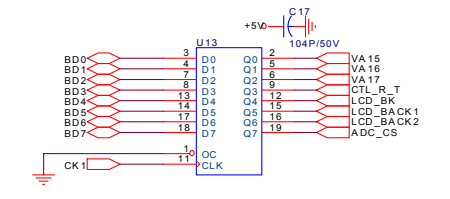
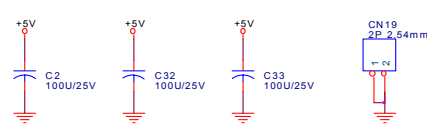
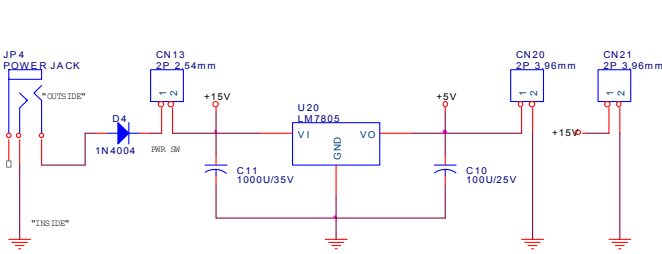
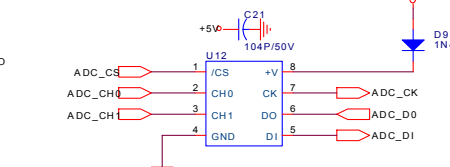
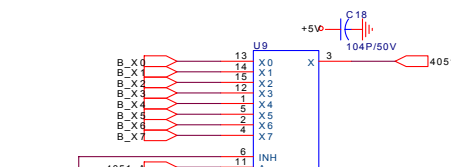
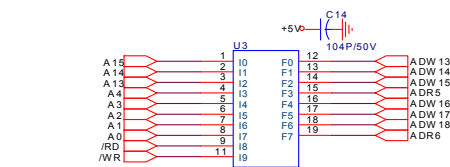
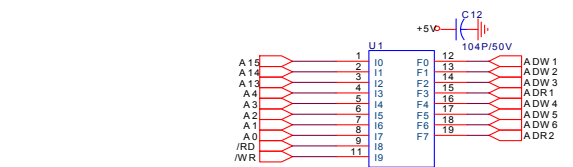
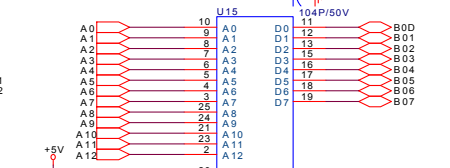
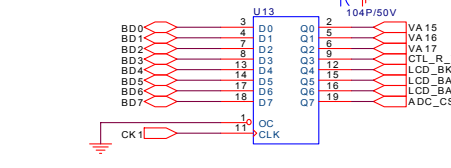
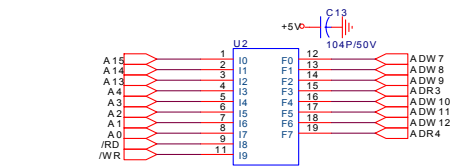
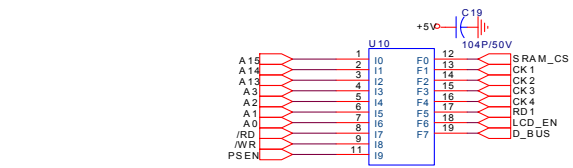
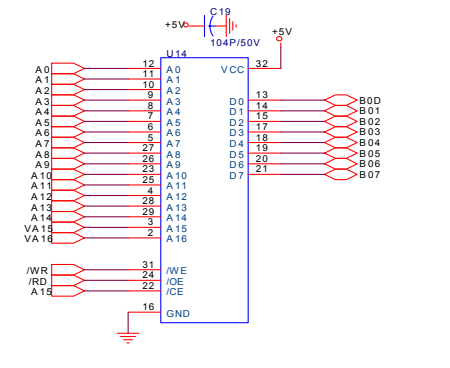
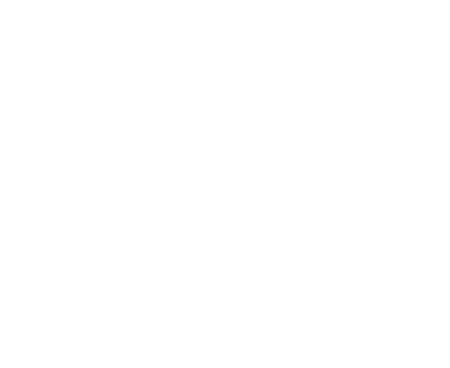
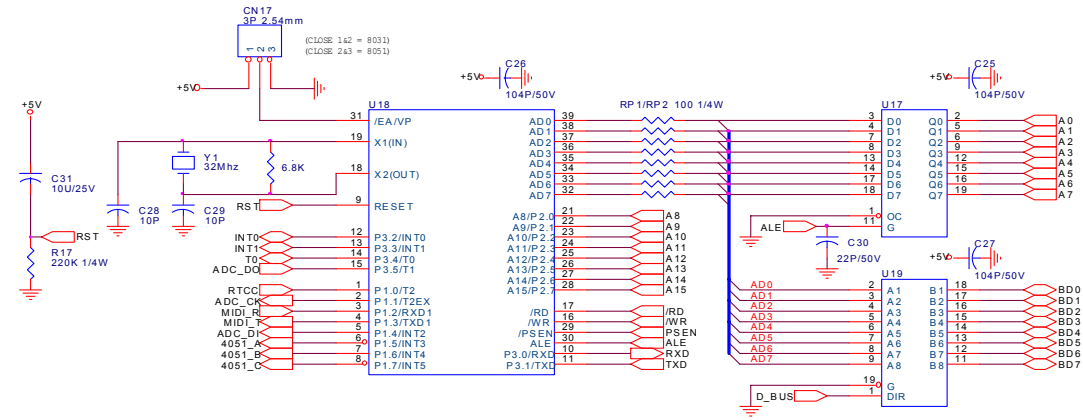

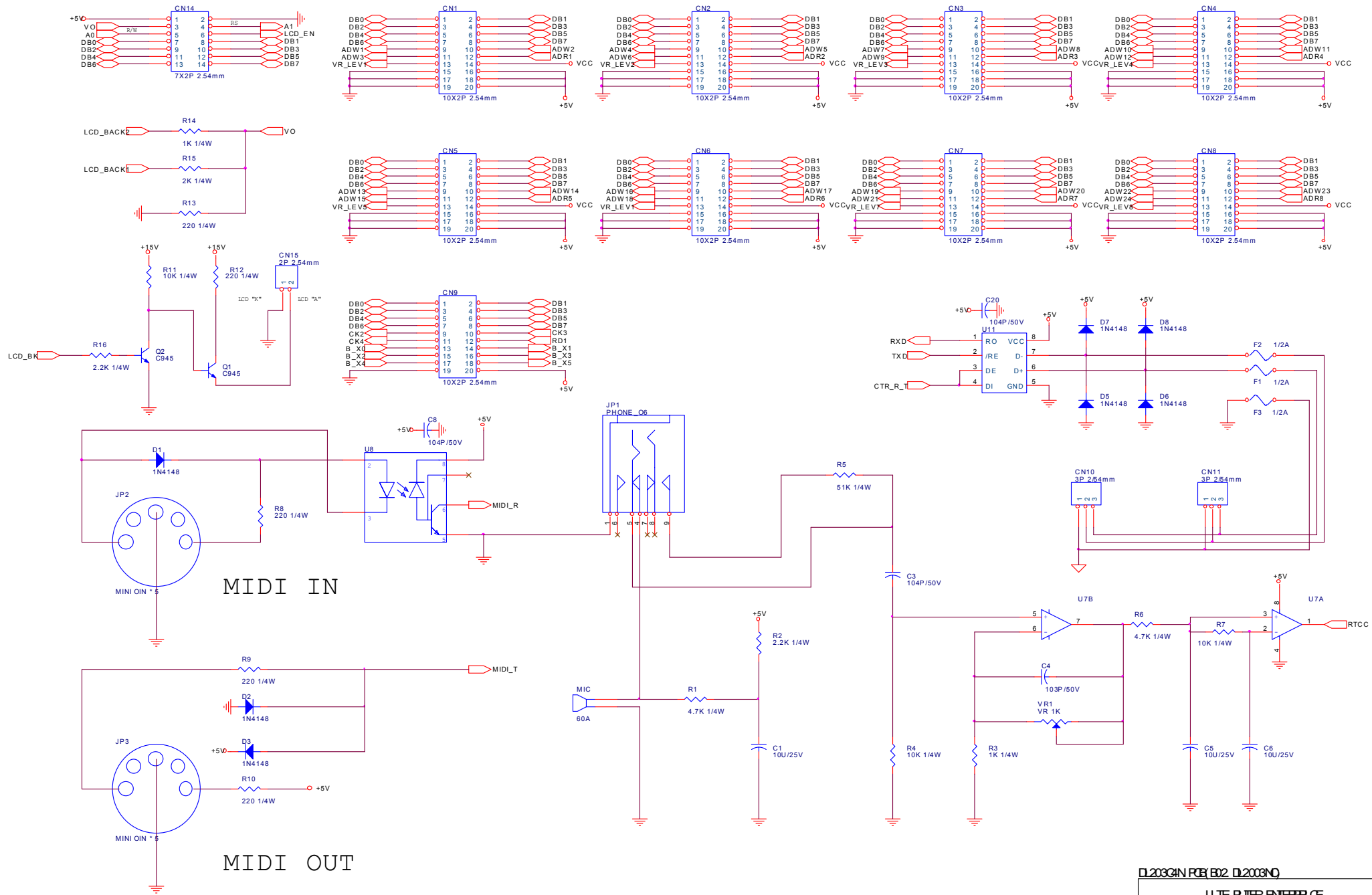

D.203CN PCB (B02, D.2038N)

LITE FINDER ENTERPRISE	
OSN DALLAS MONITOR BOARD	
File	Rev
Size	C
Document Number	D.20-304NS DEN
Date: Monday, August 18, 2003	Sheet 2 of 2

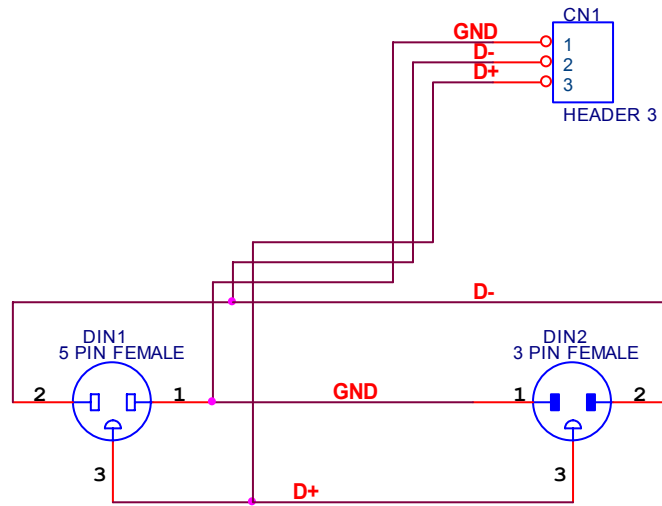

JF06A PCB (B02 JF06000A)

<p style="text-align: center;">ULITE-FUTER ENTERPRISE CO., LTD</p>		
<p style="text-align: center;">CX-5 DMX BOARD</p>		
<p>Size A</p>	<p>Document Number JF06A DSN</p>	<p>Rev A</p>
<p>Date: Friday, May 17, 2002 Sheet 1 of 1</p>		

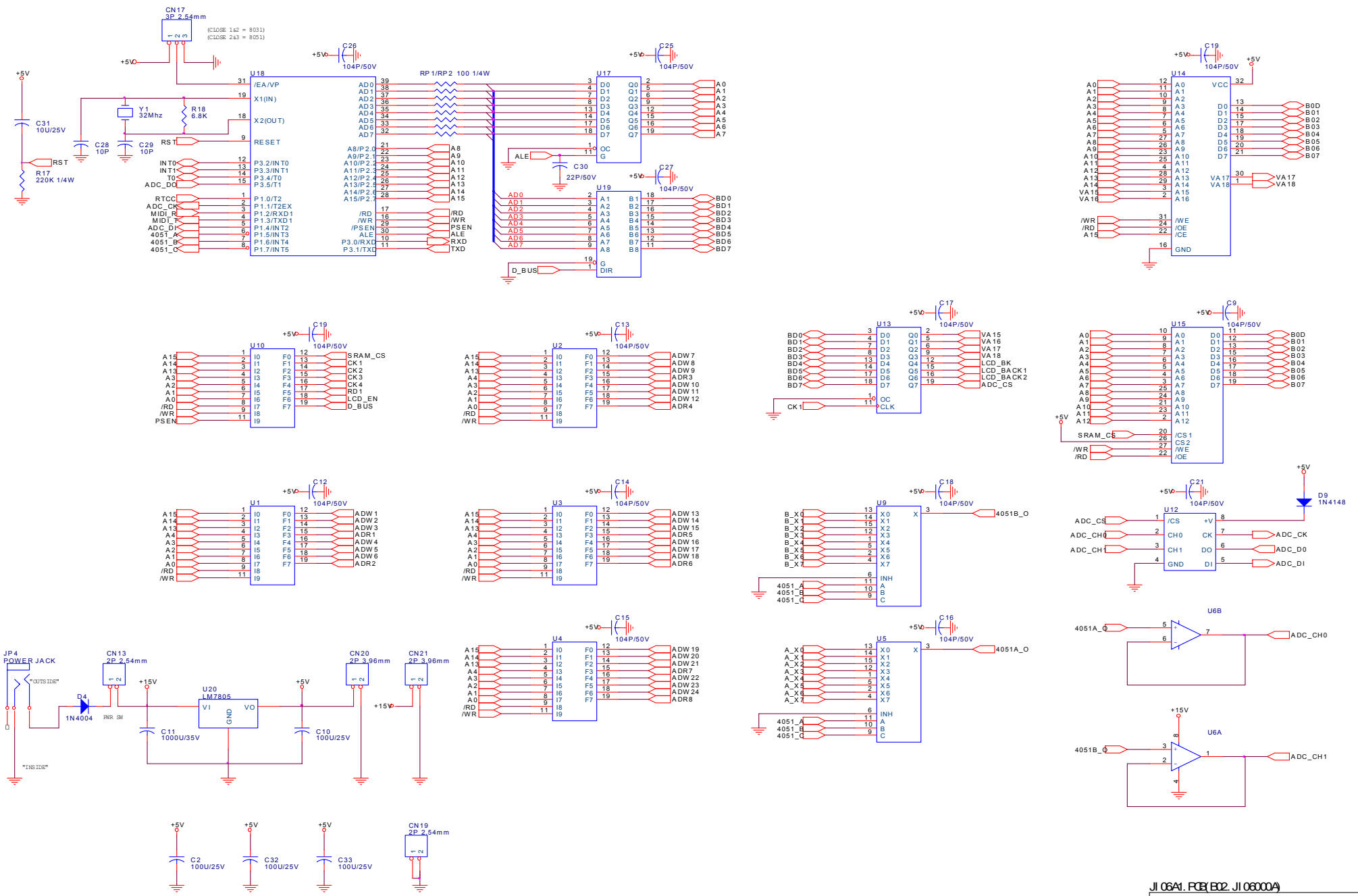

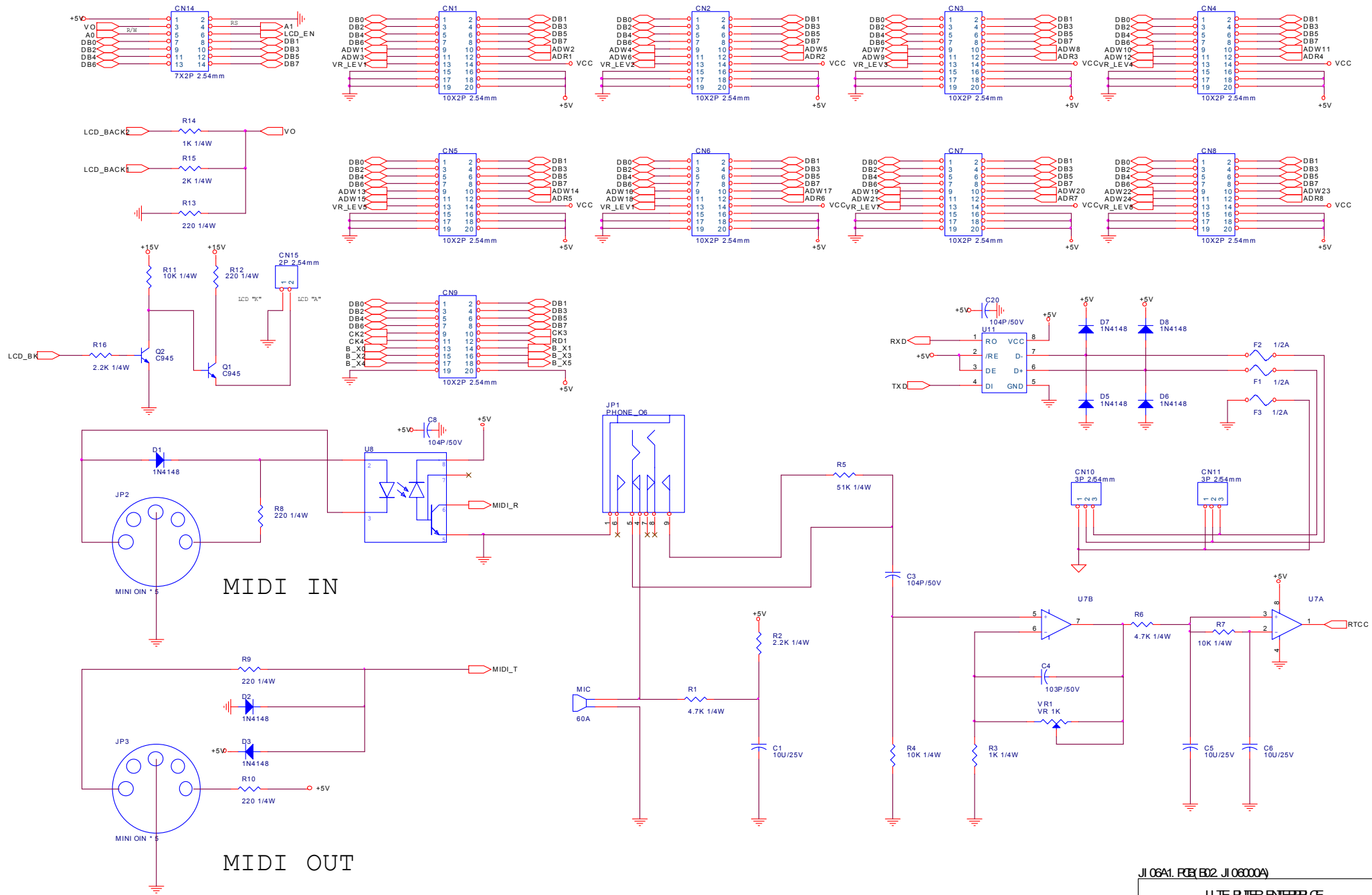

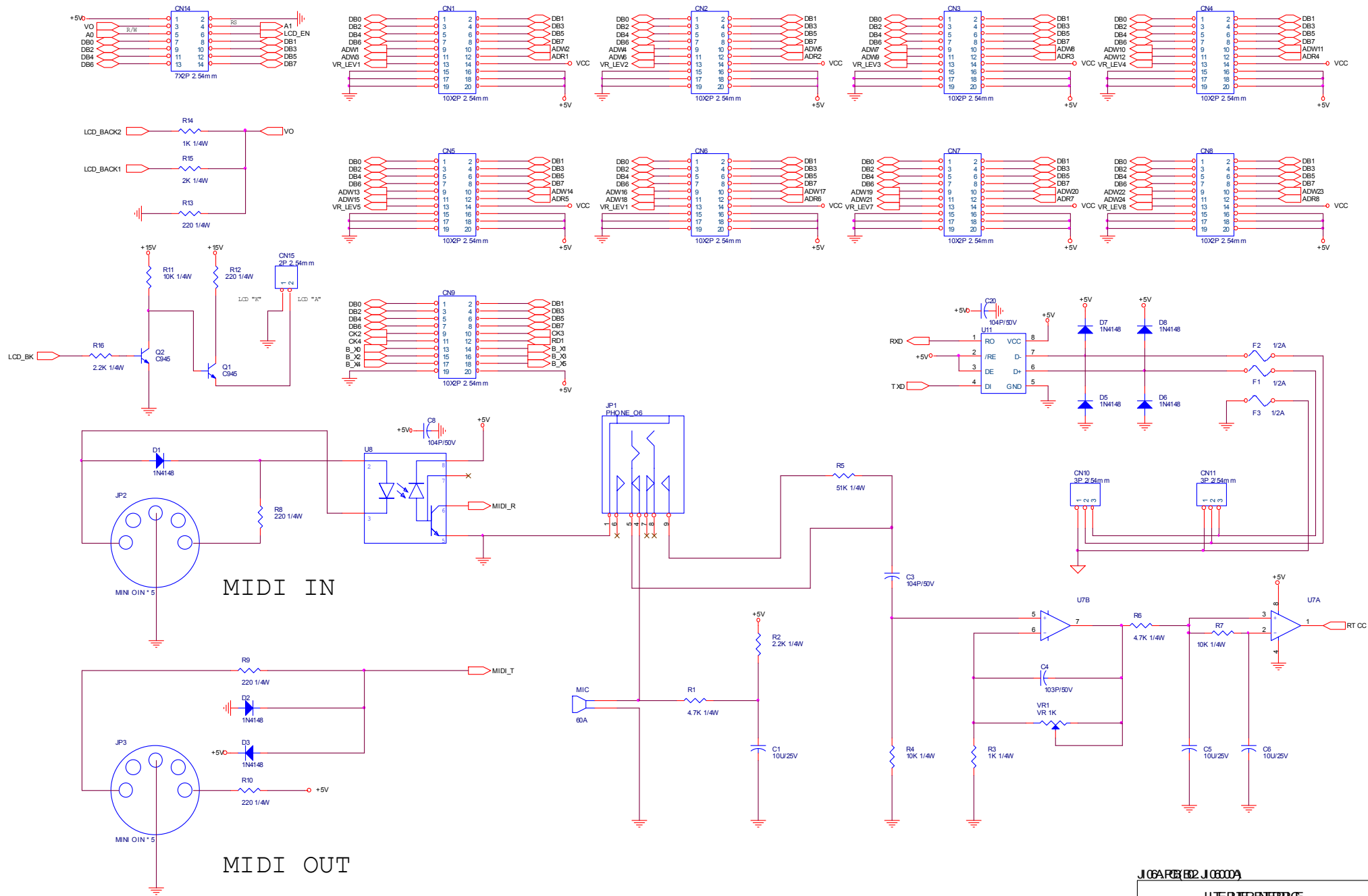

JI 06A PCB (B2) JI 06000A		
LI TERPERENBERG		
CONDALAS MONITORBOARD		
File		
Size	Document Number	Rev
C	JI 06AS (B)	A
Date:	Friday, September 06, 2002	Sheet 2 of 2